

TIGERGRIP | GX 28-50

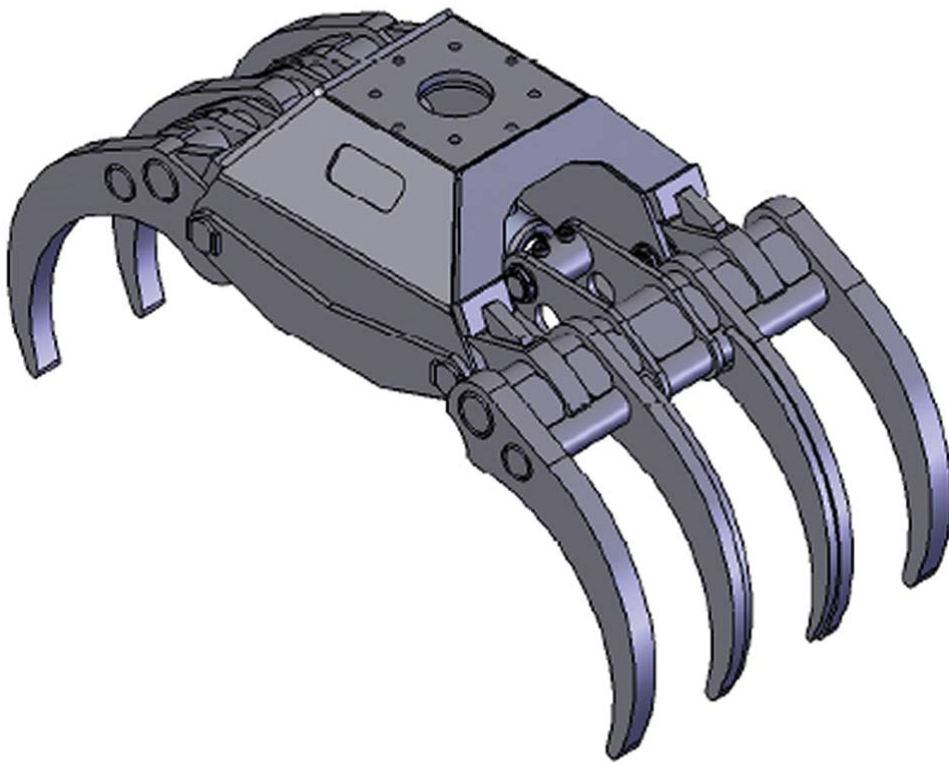

KEY FEATURES

- Heavy duty
- Dubbla parallellstag
- Optimala in- och utrullningsegenskaper
- Cylinder med dubbla kolvstångstätningar för höga tryck
- Höghållfast slitstål (400 HB)
- Extra förstärkt ok för fast montage (grävmaskinsutförande)

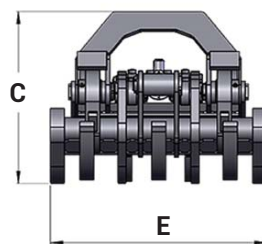
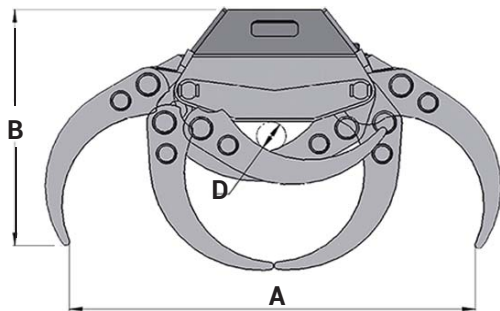

A	1471
B	783
C	622
D	100
E	760

MODEL SPECIFICATIONS



GX 28-50

495

0,28

350

60

20

30

8

20

14

OK

INTERMERCATO

High performance lift and load attachments for Forestry, Transport, Construction and Recycling.

