

# TIGERGRIP | GX 36-50

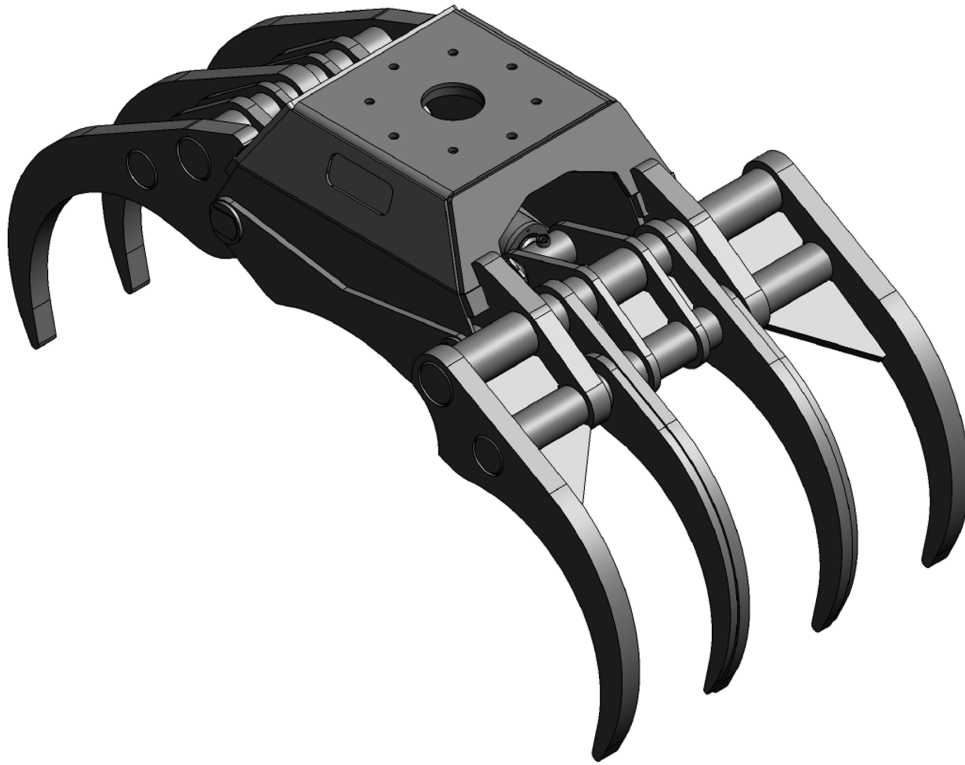

## KEY FEATURES

- Heavy duty
- Dubbla parallellstag
- Optimala in- och utrullningsegenskaper
- Cylinder med dubbla kolvstångstätningar för höga tryck
- Höghållfast slitstål (400 HB)
- Extra förstärkt ok för fast montage (grävmaskinsutförande)

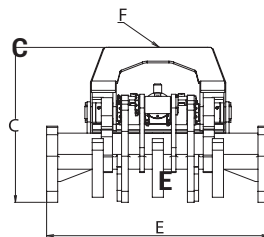
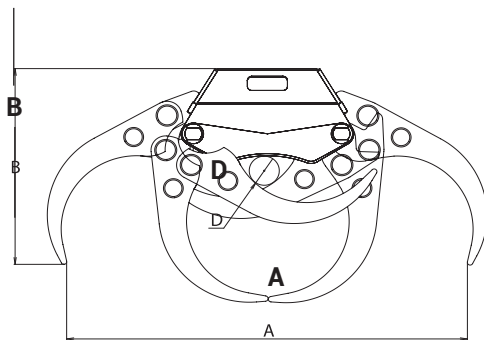

<b>A</b>	1690
<b>B</b>	954
<b>C</b>	672
<b>D</b>	120
<b>E</b>	1000

## MODEL SPECIFICATIONS



GX 36-50

860

0,36

350

60

20,5

40

10

30

22

# INTERMERCATO

High performance lift and load attachments for Forestry, Transport, Construction and Recycling.

