

# ROTECH / RMR 16 C

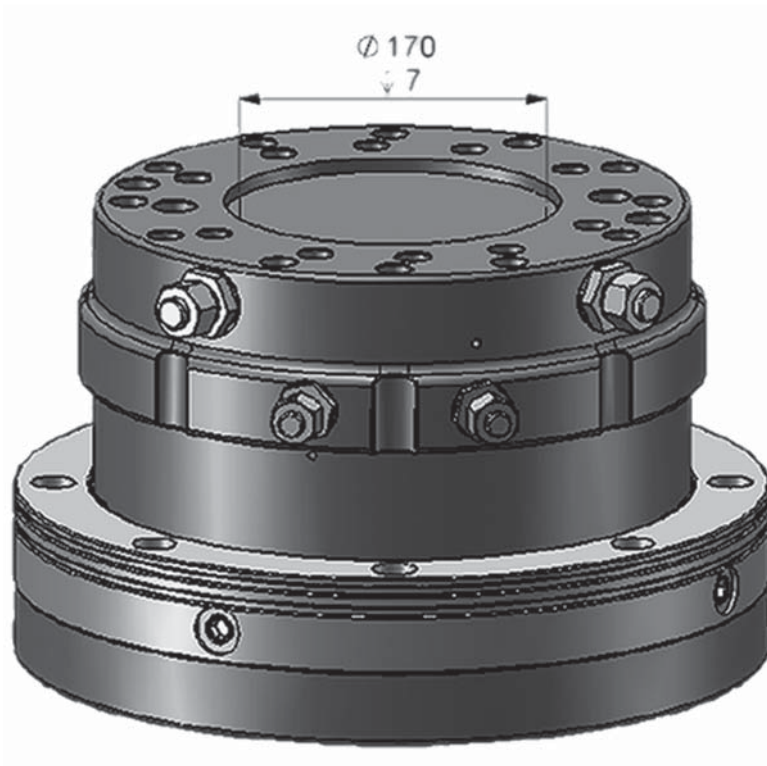

## KEY FEATURES

- High pressure construction
- Endless rotation
- High torque
- Optimized positioning performance
- Steel flange for increased durability
- Ultra compact design

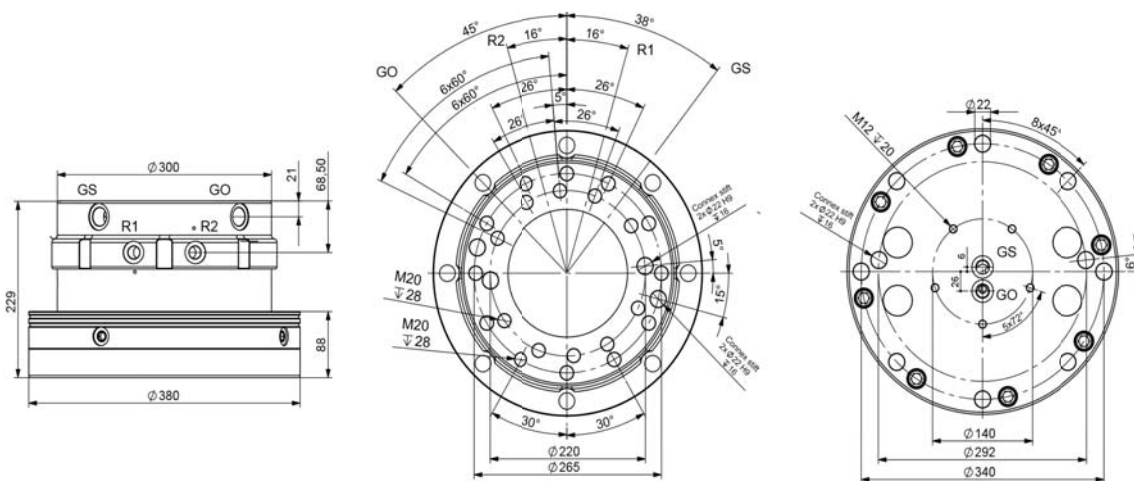

## MODEL SPECIFICATIONS



RMR 16 C

135

38

320

25

360°

4200

1/2"3/4"

38

18

# INTERMERCATO

High performance lift and load attachments for Forestry, Transport, Construction and Recycling.

