

### KEY FEATURES

- Extremt robust
- Pilotstyrd lasthållningsventil
- Dubbelverkade
- Användarvänlig
- Kan anpassas till alla rotatorer

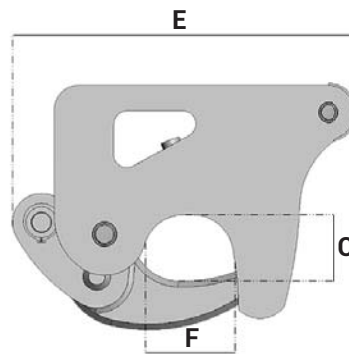
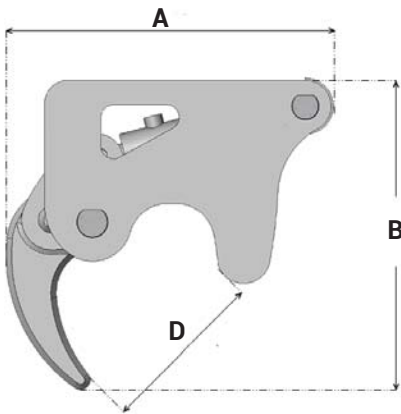

<b>A</b>	418
<b>B</b>	483
<b>C</b>	74
<b>D</b>	215
<b>E</b>	417
<b>F</b>	108

### MODEL SPECIFICATIONS



ARH 30

15

0,3

- Stängningshastighet: 2,2 sec
- Öppningshastighet: 1,5 sec
- Rotatoraxel: 50(69)/30