

TIGERGRIP | GX 55-50

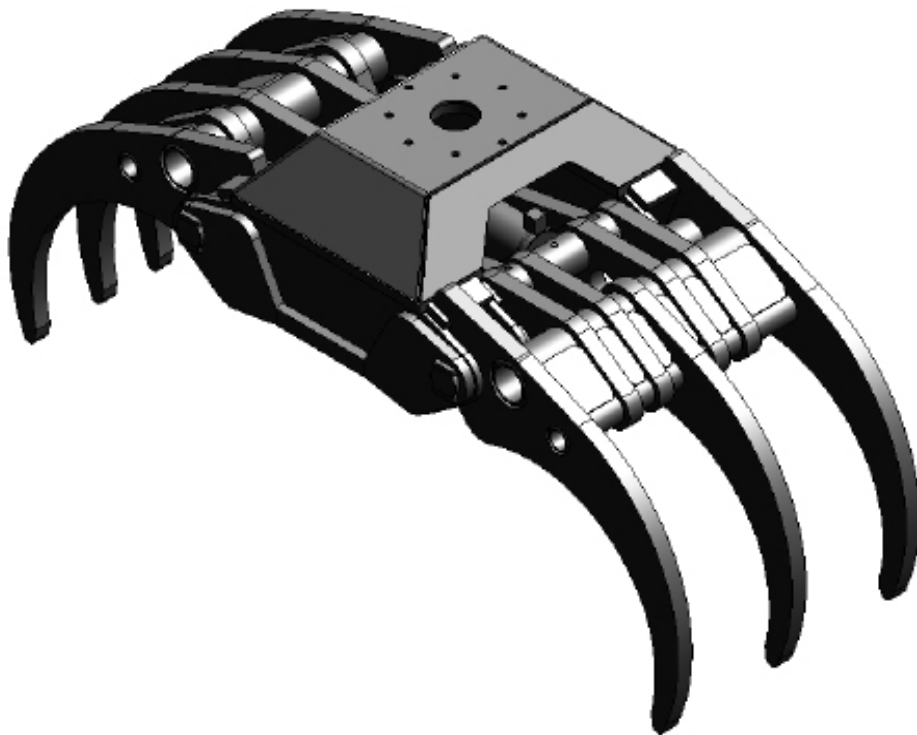

KEY FEATURES

- Heavy duty
- Dubbla parallellstag
- Optimala in- och utrullningsegenskaper
- Cylinder med dubbla kolvstångstätningar för höga tryck
- Höghållfast slitstål (400 HB)
- Extra förstärkt ok för fast montage (grävmaskinsutförande)

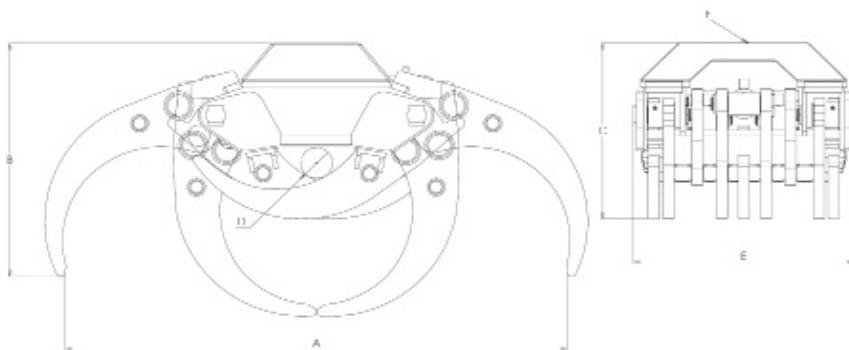

A	2295
B	1100
C	828
D	145
E	1010
F	340/8-20

MODEL SPECIFICATIONS



GX 55-50

1585

0,50

350

70

50

12

40

30

INTERMERCATO

High performance lift and load attachments for Forestry, Transport, Construction and Recycling.

