

# TIGERGRIP | DS-Grab 5 - 6

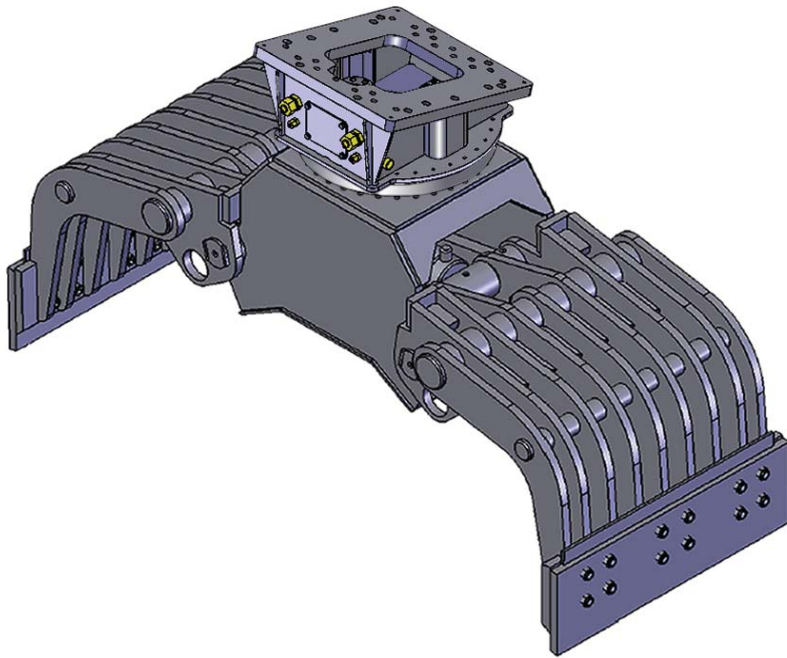

## KEY FEATURES

- Heavy duty
- Dubbla parallellstag
- Cylinder med dubbla kolstångstättningar för höga tryck
- Höghållfast slitstål (400 HB)
- Extra förstärkt ok för fast montage (grävmaskinsutförande)
- Självsmörjande bussningar
- Vändbara skär
- Skär av höghållfast slitstål
- Pilotstyrd lasthållningsventil

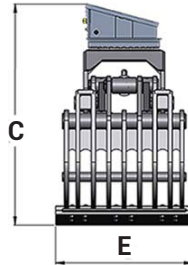
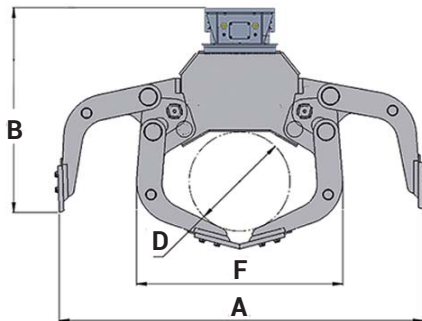

	DS-Grab 5	DS-Grab 6
A	1936	2347
B	1283	1447
C	1485	1687
D	530	650
E	800	1000
F	1085	1330

## MODEL SPECIFICATIONS



MODEL	Kg	m <sup>2</sup>	Bar	l/min	kN	ton
DS-Grab 5	1225	0,35	350	60/30	57	18-22
DS Grab 6	1770	0,50	350	90/30	69	20-25

# INTERMERCATO

High performance lift and load attachments for Forestry, Transport, Construction and Recycling.

