

TIGERGRIP / TG 16 ST

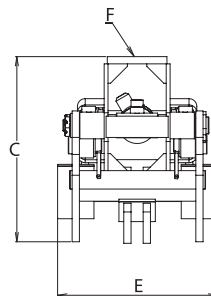

KEY FEATURES

- Heavy duty
- Dubbla parallellstag
- Optimala in- och utrullningsegenskaper
- Höghållfast slitstål (400 HB)
- Extra förstärkt ok för fast montage (grävmaskinsutförande)

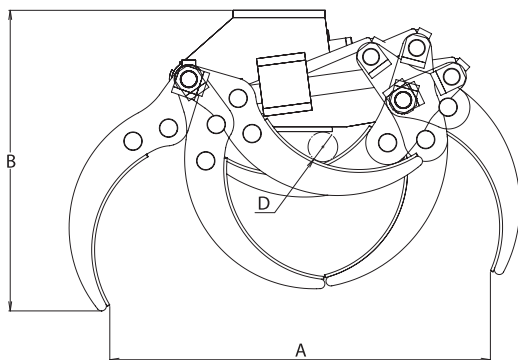

A	785
B	520
C	387
D	55
E	330
F	140x140

MODEL SPECIFICATIONS



TG 16 ST	65	0,16	200	40	9	3	1	3	2			
----------	----	------	-----	----	---	---	---	---	---	--	--	--

INTERMERCATO

High performance lift and load attachments for Forestry, Transport, Construction and Recycling.

