

Timmergripare

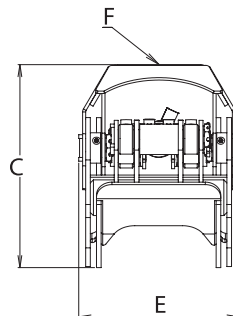
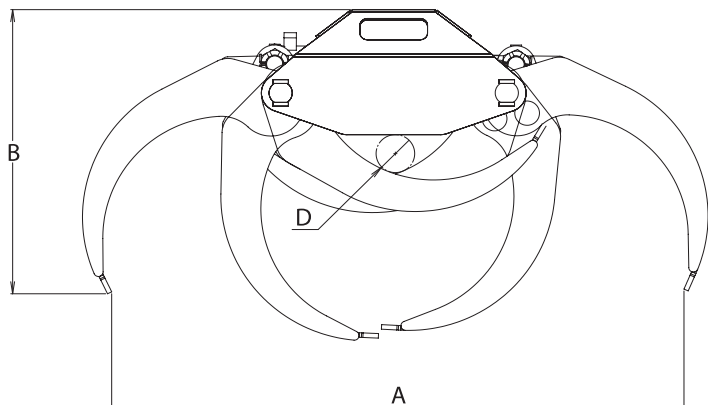

KEY FEATURES

- Dubbla parallellstagar
- Optimala in- och utrullningsegenskaper
- Cylinder med dubbla kolvstängstätningar för höga tryck
- TG 22 PRO-L - TG 55 har klor tillverkade i Hardox

	TG 08	TG 12	TG 16	TG 19	TG 22	TG 22-50	TG 22 PRO-L	TG 23	TG 25	TG 28	TG 35	TG 42	TG 55
A	690	765	933	1120	1287	1287	1200	1262	1450	1485	1880	1831	2445
B	465	610	590	704	594	624	623	631	746	750	807	982	1020
C	300	366	400	454	509	539	446	465	510	535	594	676	795
D	32	38	60	47	87	87	65	55	40	100	65	100	150
E	224	263	287	291	311	311	432	401	371	416	502	516	563
F	40/20	50/25	50/25	50/25	173/4	50/25	173/6	140x140	173/6	173/6	173/6	173/6	173/6

MODELLSPEC.



MODEL	Kg	m ²	Bar	l/min	kN	tm	ton
TG 08	25	0,08	160	15	4	0,5	0,3
TG 12	44	0,12	200	30	8	2	0,6
TG 16-50/59	50	0,16	200	40	9	2	0,8
TG 19	67	0,18	200	40	10	2,5	1
TG 22	98	0,22	200	50	13,5	3	1,5
TG 22-50/59	98	0,22	200	50	13,5	3	1,5
TG 22 PRO-L	128	0,20	250	50	14,5	5	2
TG 23	120	0,23	200	50	13,5	3	1,5
TG 25	138	0,25	200	50	11	3	2
TG 28	185	0,30	250	60	16,6	8	3
TG 35	292	0,38	250	60	17,5	15	5
TG 42	370	0,50	250	70	21,8	17	5
TG 55	560	0,65	250	90	25	30	7



TG 12

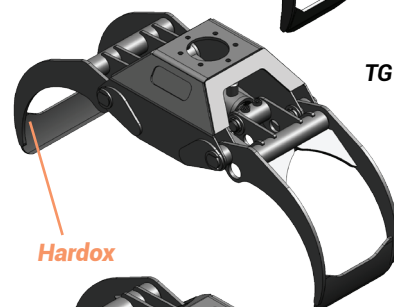

TG 22 PRO-L

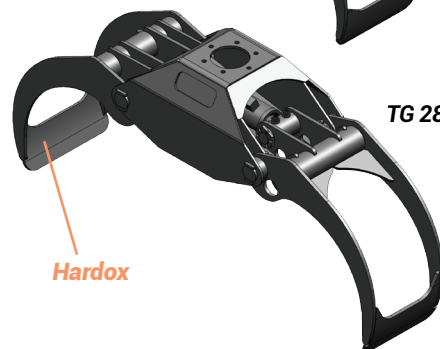

TG 28