

## T-Cut Tree shears

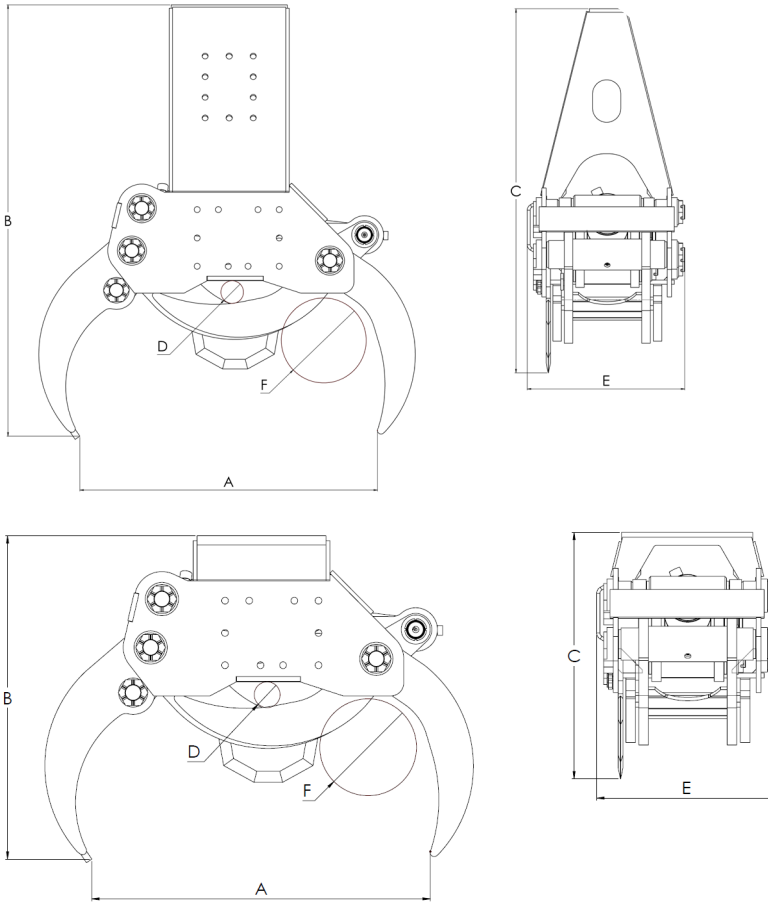

We accept no substitutes. The "Hardox In My Body" sign on our equipment is your guarantee of genuine Hardox wear plate.



	T-Cut 18	T-Cut 25	T-Cut 30	T-Cut 40
<b>A</b>	26	35,1	41,4	54,1
<b>B</b>	40	51,3	59,9	70,5
<b>C</b>	33,8	43,4	50,6	58,7
<b>D</b>	1,6	3,1	3,1	3,9
<b>E</b>	16,1	19,9	21,9	27,8
<b>F</b>	6,3	9,8	11,8	15,7

	T-Cut 18R	T-Cut 25R	T-Cut 30R
<b>A</b>	26	35,1	41,4
<b>B</b>	25,7	32,6	39,4
<b>C</b>	19,4	24,7	30
<b>D</b>	1,6	3,1	3,1
<b>E</b>	16,1	19,9	21,9
<b>F</b>	6,3	9,8	11,8

### MODEL SPECIFICATIONS



MODEL	Weight (lb)	Pressure (psi)	Flow rate (gpm)	Force (lbf)	Capacity (lb)	Cutting diam.*
T-Cut 18	375	3625	8	9670	4410-11020	7,1
T-Cut 25	736	3625	16	13040	13230-35270	9,8
T-Cut 30	1131	3625	18,7	19780	26460-44090	11,8
T-Cut 40	2249	4350	26,7	26980	39680-79370	15,7
T-Cut 18R	353	3625	8	9670	4410-11020	7,1
T-Cut 25R	617	3625	16	13040	11020-26460	9,8
T-Cut 30R	1025	3625	18,7	19780	26460-39680	11,8

\*Softwood

T-CUT 30

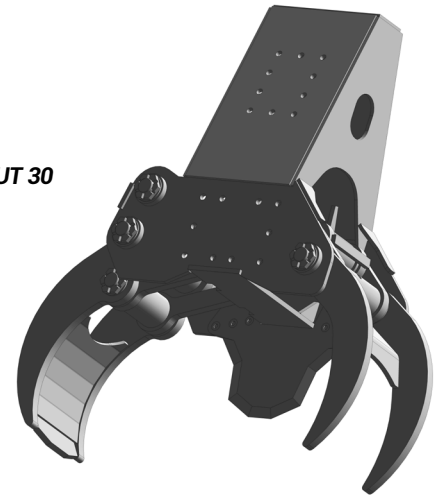

T-CUT 30 FOR ROTATOR

