

KEY FEATURES

- Double guide bars
- Cylinder with double piston rod seals for high pressure
- Pilot-operated check valve
- 2-t welded hooks
- Cutting edges made of Hardox

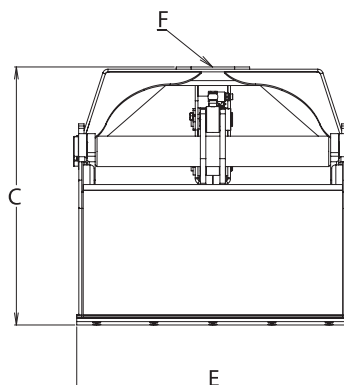
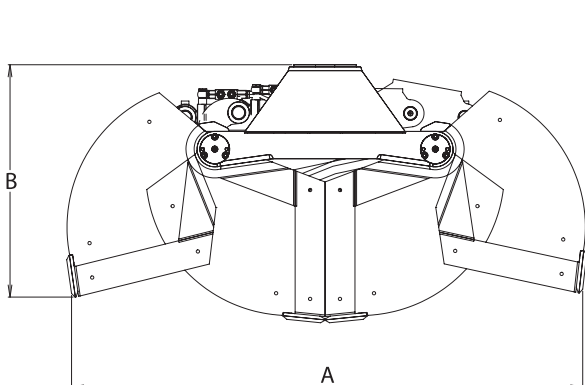

	TVG 650	TVG 800	TVG 1000
A	1862	1862	1862
B	837	837	837
C	1310	1310	1310
E	650	800	1000
F	140x140	140x140	140x140

MODEL SPECIFICATIONS



Model	Kg	Lt	Bar	l/min	kN	ton	tm/min
TVG 650	410	350	250	60	28	3	25
TVG 800	475	400	250	60	28	3	25
TVG 1000	520	500	250	60	28	3	25