

Indexator / G121

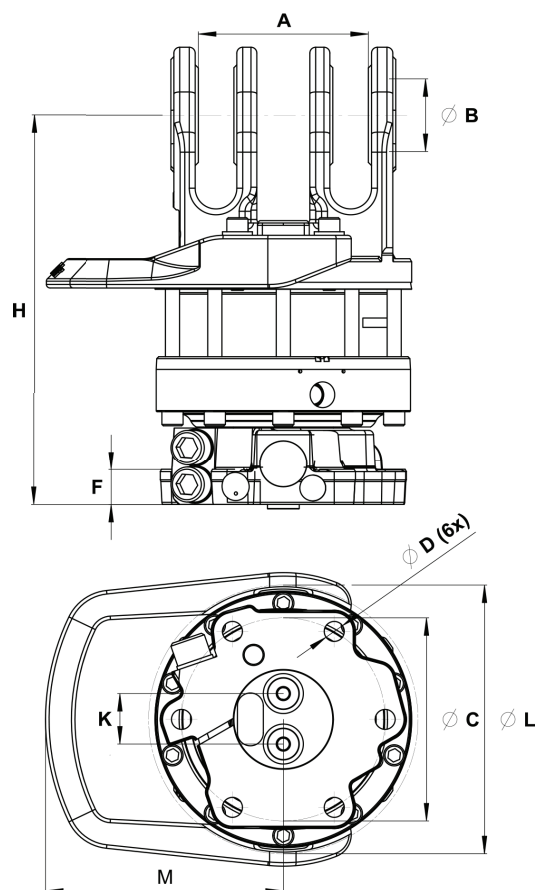

KEY FEATURES

- Endless rotation
- High torque
- Optimized positioning performance
- Hose protection included



A	MPB1
B	ØMPB
C	Ø173
D	Ø17
F	30
H	333
K	42
L	Ø229
M	202

MODEL SPECIFICATIONS



G121

57,1

10

250

25

360°

2200

1/2"

INTERMERCATO®

High performance lift and load attachments for Forestry, Transport, Construction and Recycling.

