

Indexator / GV 17 US-203

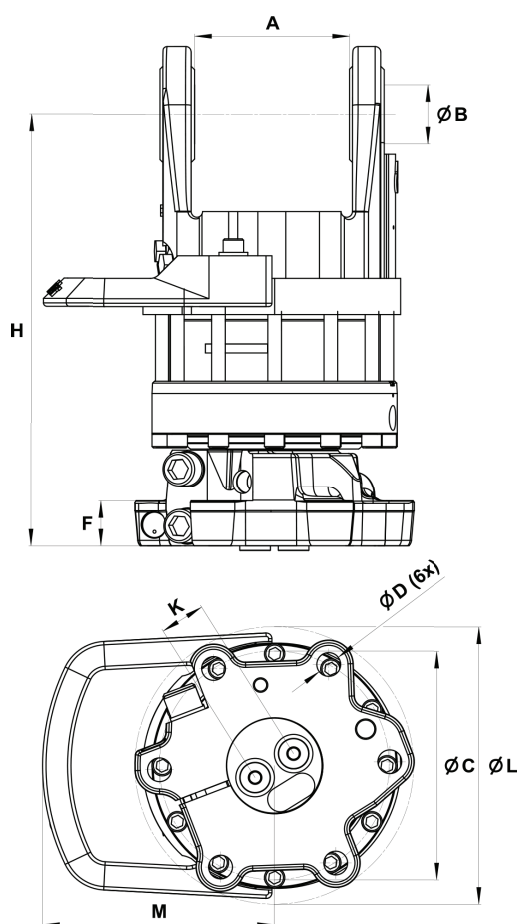

KEY FEATURES

- Endless rotation
- High torque
- Optimized positioning performance
- Hose protection included



A	80,5
B	Ø35
C	Ø173
D	Ø17
F	30
H	317
K	38,5
L	Ø209
M	404

MODEL SPECIFICATIONS



GV 17 US-203

63,8

17

250

35

360°

3300

1/2"

INTERMERCATO®

High performance lift and load attachments for Forestry, Transport, Construction and Recycling.

