

Indexator / XR 400

KEY FEATURES

- Designed for high pressures
- Endless rotation
- Optimized positioning performance
- High torque
- Ultra compact design

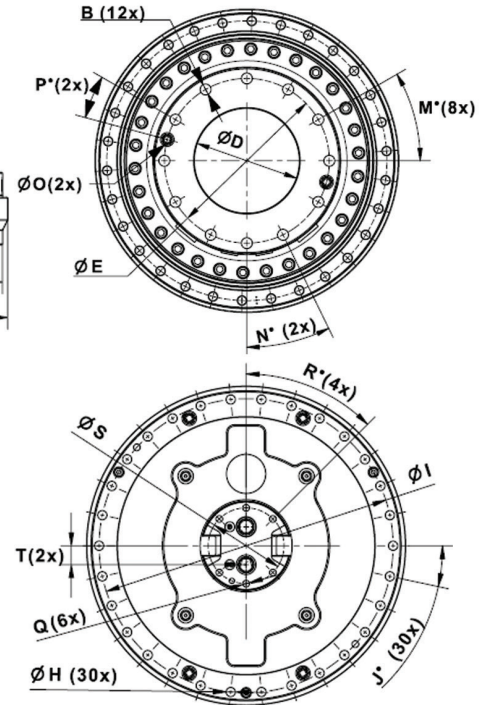
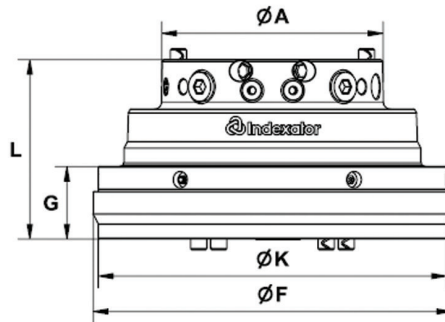

A	B	D	E	F	G	H	I	L
300	M20	170	265	488	99	14	450	244



MODEL SPECIFICATIONS



XR 400	180	55	250/400	35	360°	4100	1/2"/1"
--------	-----	----	---------	----	------	------	---------

INTERMERCATO®
HIGH PERFORMANCE LIFT & LOAD ATTACHMENTS

High performance lift and load attachments for Forestry, Transport, Construction and Recycling.

