

Indexator / GV 12 S



PRINCIPAIS CARACTERÍSTICAS

- Rotação infinita
- Binário elevado
- Desempenho de posicionamento otimizado
- Proteção de mangueira incluída

A	101
B	Ø45
C	Ø173
D	Ø17
F	30
H	333
K	38,5
L	Ø209
M	202

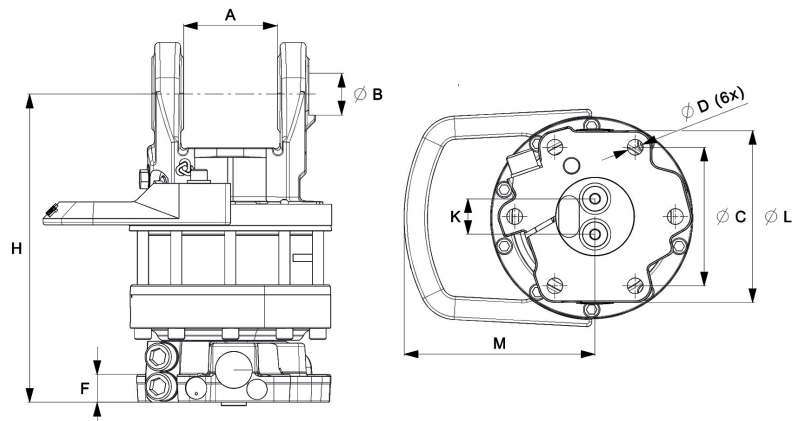

ESPECIFICAÇÕES DO MODELO



GV 12 S

57,7

10

250

25

360°

2200

1/2"

INTERMERCATO®
HIGH PERFORMANCE LIFT & LOAD ATTACHMENTS

Elevadores e acessórios de carga de alto desempenho para Silvicultura, Transporte, Construção e Reciclagem.

